



CE

119GM47EN

AUTOMATIC CHAIN-BARRIERS



INSTALLATION MANUAL

CAT-X24



English

EN



WARNING!
important safety instructions for people:
READ CAREFULLY!



Premise

- Employ this product only for the use for which it was expressly made. Any other use is dangerous. CAME S.p.A is not liable for any damage caused by improper, wrongful and unreasonable use
- The safety of this product and its proper fitting depends, therefore, on respecting its technical characteristics and proper fitting, to be done in state-of-the-art fashion, and under safe conditions as expressly explained in the literature that comes with the product.
- Keep these warnings together with the installation and operation manuals that come with the operator.

Before installing

(checking what's there: if something is missing, do not continue until you have complied with all safety provisions)

- Fitting and testing must be only performed by qualified technicians
- Laying the cables, installation and testing must follow state-of-the-art procedures as dictated by regulations
- Before beginning any operation it is mandatory to carefully read all instructions; improper installation may result in serious harm to people and things.
- Make sure the barrier is in good mechanical state, balanced and aligned, and that it opens and closes properly. Also, if needed, fit suitable protections or use proper safety-sensors
- If the operator is to be installed at a height of less than 2.5 m from the ground or other access level, make sure you have any necessary protections and/or warnings in place
- Make sure that the automatic barrier cannot cause hazardous situations
- Do not install the operator upside down or onto elements that could yield and bend. If necessary, add suitable reinforcements to the anchoring points
- Do not install on tilted surfaces
- Make sure any sprinkler systems cannot wet the operator from the ground up.

Installing

- Suitably section off and demarcate the entire installation site to prevent unauthorized persons from entering the area, especially minors and children
- Be careful when handling operators that weigh over 20 Kg. If need be, use proper safety hoisting equipment
- The CE-marked safety devices (photocells, stepping plates, sensitive safety-edges, emergency buttons, and so on), must be fitted in compliance with the regulations in effect and according to state-of-the-art criteria, taking into account the environment, the type of required service and of the working forces applied to moving leaves. Any shearing or conveying points must be sensor-protected
- Any residual risks must be pointed out to end users and highlighted with pictograms as provided by the law.
- All opening commands (that is, buttons, key switches, magnetic readers, and so on) must be installed at least 1.85 m from the perimeter of the barrier's working area, or where they cannot be reached from outside the barrier. Also, any direct commands (buttons, touch panels, and so on) must be installed at least 1.5 m from the ground and must not be reachable by unauthorized persons
- The automatic barrier must visibly show its identification data.
- Before connecting the main power supply make sure that the identification data correspond to the those of the network
- The automatic barrier must be connected to an effective regulation grounding system.
- The manufacturer declines any liability for using non-original products; which would result in warranty loss
- All maintained action commands, must be fitted in places from which the moving barrier and transit and driving areas are visible
- Apply, if missing, a permanent sign showing the position of the release device.
- Before delivering to the users, make sure the system is EN 12453 and EN 12445 standard compliant (regarding impact forces), and also make sure the system has been properly adjusted and that any safety, protection and manual release devices are working properly
- Apply Warning Signs where necessary and in a visible place (such as the gate's license plate)

Special user-instructions and recommendations

- Keep barrier operation areas clean and free of any obstructions. Make sure the photocell's operating field is clear of any obstructions
- Do not allow children to play with fixed commands, or to loiter in the barrier's maneuvering area. Keep any remote control transmitters or any other command device away from children, to prevent the operator from being accidentally activated
- Frequently check the system for any malfunctions or signs of wear and tear or damage to the

- moving structures, to the component parts, all anchoring points, including cables and any accessible connections. Keep any hinges, moving joints and slide rails properly lubricated
- Perform functional checks on the photocells and sensitive safety edges, every six months. Constantly clean the photocells' glass covers using a slightly water-moistened cloth; do not use solvents or chemicals that could damage the devices
- If repairs or modifications are required to the system, release the operator and do not use it until safety conditions have been restored
- Cut off the power supply before releasing the operator for manual openings and before any other operation, to prevent potentially hazardous situations. Read the instructions
- It is FORBIDDEN for users to perform any OPERATIONS THAT ARE NOT EXPRESSLY REQUIRED OF THEM AND WHICH ARE NOT LISTED in the manuals. For any repairs, modifications and adjustments and for extra-ordinary maintenance, CALL TECHNICAL ASSISTANCE
- Log the job and checks into the periodic maintenance log.

Further recommendations for all

- Keep away from and do not loiter near the barrier and mechanical moving parts
- Do not enter the barrier's area of operation when it is moving
- Do not counter the operator's movement as this could result in dangerous situations
- Always pay special attention to any dangerous points, which have to be labeled with specific pictograms and/or black and yellow stripes
- When using a selector switch or a command in maintained actions, keep checking that there are no persons within the operating range of any moving parts, until the command is released
- The barrier may move at any time and without warning
- Always cut off the power supply before performing any maintenance or cleaning.

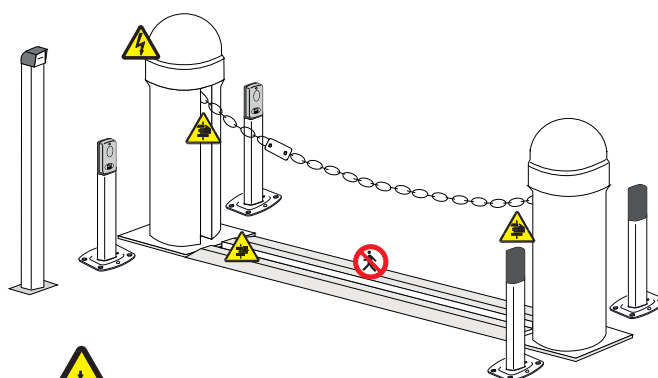

Danger of hand crushing



Danger of foot crushing





Danger! High voltage.



No transiting while the barrier is moving

LEGEND

-  This symbol shows which parts to read carefully.
-  This symbol shows which parts describe safety issues
-  This symbol shows which parts to tell users about.

REFERENCE REGULATIONS

Came S.p.A. the company is quality and environmentally certified by the ISO 9001 and the ISO 14001 respectively, for its management systems. This product complies with the current regulations mentioned in the declaration of conformity.

DESCRIPTION

| | |
|--------------------|---|
| 001 CAT-X24 | Pillar with gearmotor and built-in control panel. |
| 001 CAT-I | Pillar with counter-weight and chain hook. |

Intended use

The CAT-X24 operator is designed for use in either private or public parking facilities and in residential areas.

 Any installation and/or use other than that specified in this manual is forbidden.

Limits to use

| Model | CAT-15 (5 mm chain) | CAT-5 (9 mm chain) |
|------------------------------------|---------------------|--------------------|
| Maximum width of passage width (m) | 16 | 8 |

Technical data

| Type | CAT-X24 | CAT-I |
|-----------------------------|---------------|-------|
| Protection rating (IP) | 54 | - |
| Power supply (V - 50/60 Hz) | 230 AC | - |
| Power supply motor (V) | 24 DC | - |
| Max draw (A) | 10 | - |
| Power (W) | 240 | - |
| Maneuver time (s) | ADJUSTABLE | - |
| Duty cycle (%) | INTENSIVE USE | - |
| Towing force (kg) | 50 | - |
| Operating temperature (°C) | -20 ÷ 55 | - |
| Weight (kg) | 47 | 30 |

Description of parts

1. Cap fastening screw
2. Cap
3. Side protective carters
4. Control panel
5. Frame
6. Gearmotor
7. Anchoring plate
8. Anchoring clamps with nuts and bolts
9. Chain-slide pulley
10. Service chain with hooking terminal
11. Chain-winding pulley
12. Key release
13. Counter-weight
14. Service chain with hooking lock

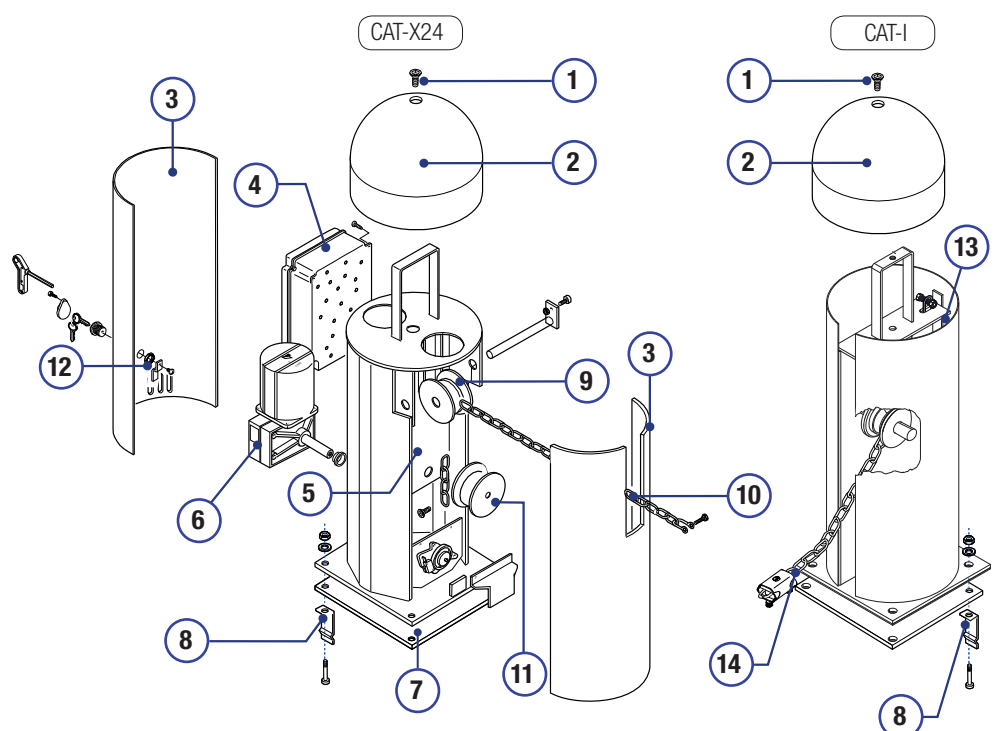

Dimensions

(mm)

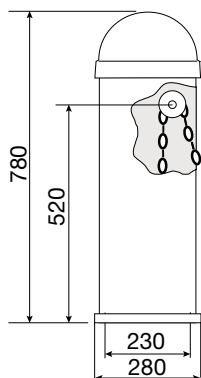

Standard installation

1. CAT-X24
2. CAT-I
3. Control panel
4. Blocking chain
5. Outer chain-protecting guide
6. Small post
7. Selector
8. Coil
9. Photocell
10. Small photocell post
11. Flashing light with antenna

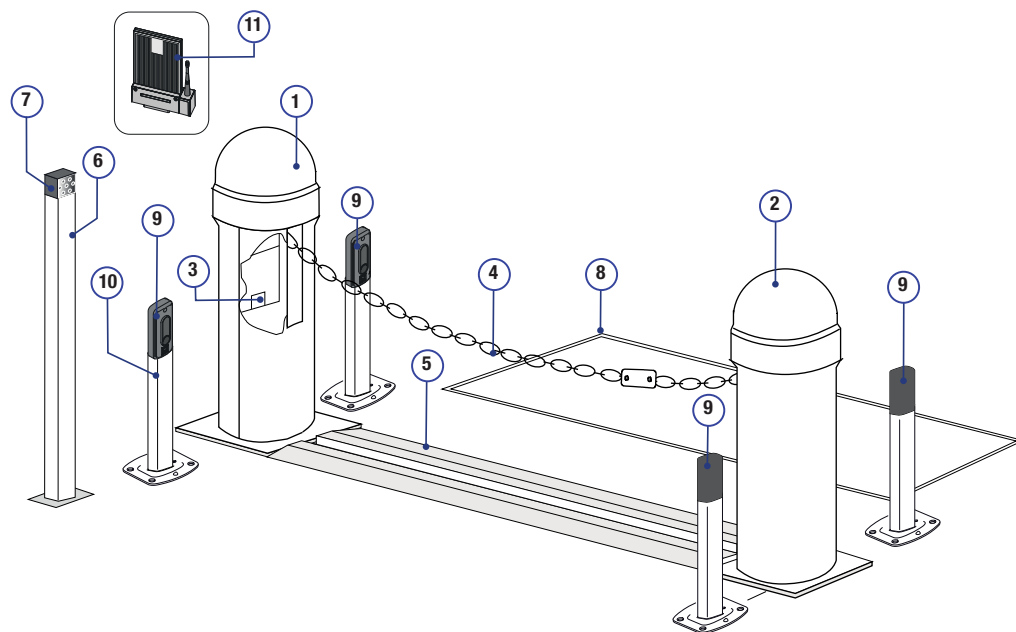

GENERAL INSTRUCTIONS FOR INSTALLING

- ⚠ Only skilled, qualified staff must install this product.
- 📖 Use original accessories for easier fitting and maintenance.

Preliminary checks

- ⚠ Before fitting the operator:
 - make sure the guide is properly fitted to the floor
 - ⊕ make sure that any connections inside the casing (ones that ensure continuity to the protection circuit) are fitted with additional insulation with respect to those of other electrical parts inside
 - set up suitable tubes and conduits for the electric cables to pass through, making sure they are protected from any mechanical damage.

Tools and materials

Make sure you have all the tools and materials you will need for installing in total safety and in compliance with applicable regulations. The figure shows some of the equipment installers will need.

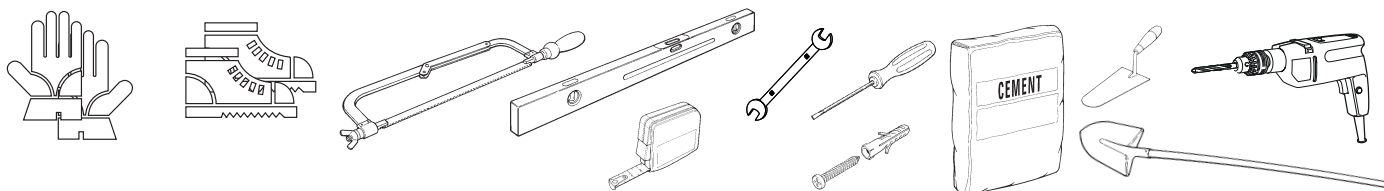

Cable types and minimum thicknesses

| Connection | Cable type | Cable length 1 < 10 m | Cable length 10 < 20 m | Cable length 20 < 30 m |
|-------------------------------------|---------------------------------------|--------------------------|---------------------------|---------------------------|
| Control panel power supply 230 V AC | FROR CEI 20-22 CEI EN 50267-2-1 | 3G x 1.5 mm ² | 3G x 2.5 mm ² | 3G x 4 mm ² |
| Flashing light | | 2 x 0.5 mm ² | 2 x 1 mm ² | 2 x 1.5 mm ² |
| Photocell transmitters | | 2 x 0.5 mm ² | 2 x 0.5 mm ² | 2 x 0.5 mm ² |
| Photocell receivers | | 4 x 0.5 mm ² | 4 x 0.5 mm ² | 4 x 0.5 mm ² |
| Command and control devices | | 2 x 0.5 mm ² | 2 x 0.5 mm ² | 2 x 0.5 mm ² |
| Antenna | RG58 | max 10 m | | |

📖 If cable lengths differ from those specified in the table, establish the cable sections depending on the actual power draw of the connected devices and according to the provisions of regulation CEI EN 60204-1.

For multiple, sequential loads along the same line, the dimensions on the table need to be recalculated according to the actual power draw and distances. If connecting products that are not contemplated in this manual, see the literature accompanying said products

INSTALLATION

⚠ The following illustrations are mere examples. Consider that the space available where to fit the operator and accessories will vary depending on the overall measurements. It is up to each installer to select the most suitable solution.

Laying the corrugated tubes and protective guide

Excavate a hole for the foundation box and chain-protection guide (CAR-4). Set up the corrugated tubes needed for making the connections coming out of the junction pit. To connect the gearmotor we suggest a Ø 60 mm corrugated tube. Whereas for the accessories we suggest Ø 25 mm tubes.

📖 The number of tubes depends on the type of system and the accessories you are going to fit.

⚠ In public areas, the CAR-2 and CAR-4 guides must be clearly demarcated with suitable signs and/or slanted yellow and black painted stripes, to warn against possible tripping and foot entrapment.

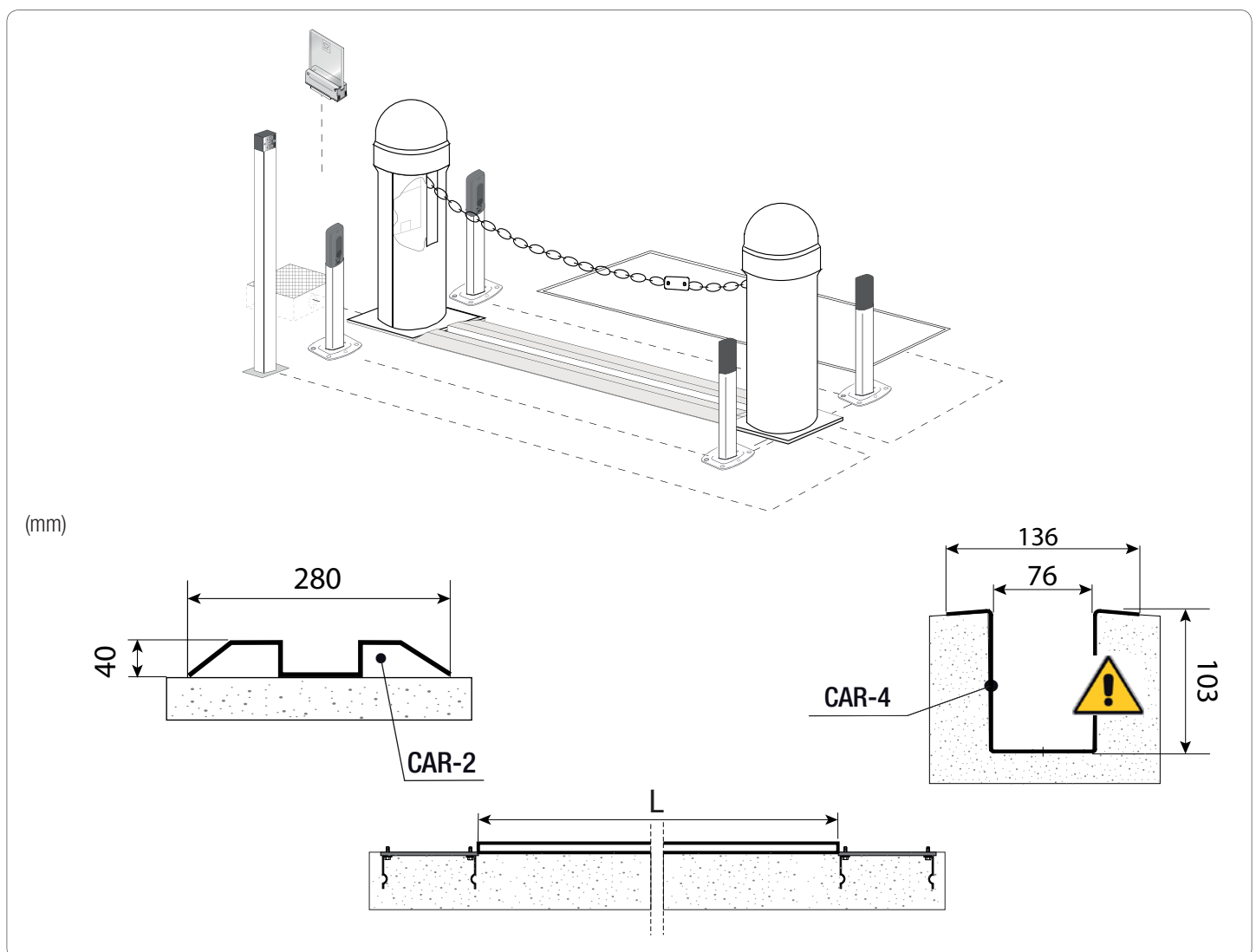

Laying the anchoring plate

Set up a foundation frame that is larger than the anchoring plate and sink it into the dug hole. When using the CAR-2, the foundation frame must jut out by 50 mm above ground level.

Fit an iron cage into the foundation frame to reinforce the concrete.

Fasten the anchoring clamps to the plate by using the supplied screws, washers and nuts.

⚠ The tubes must run through the existing holes.

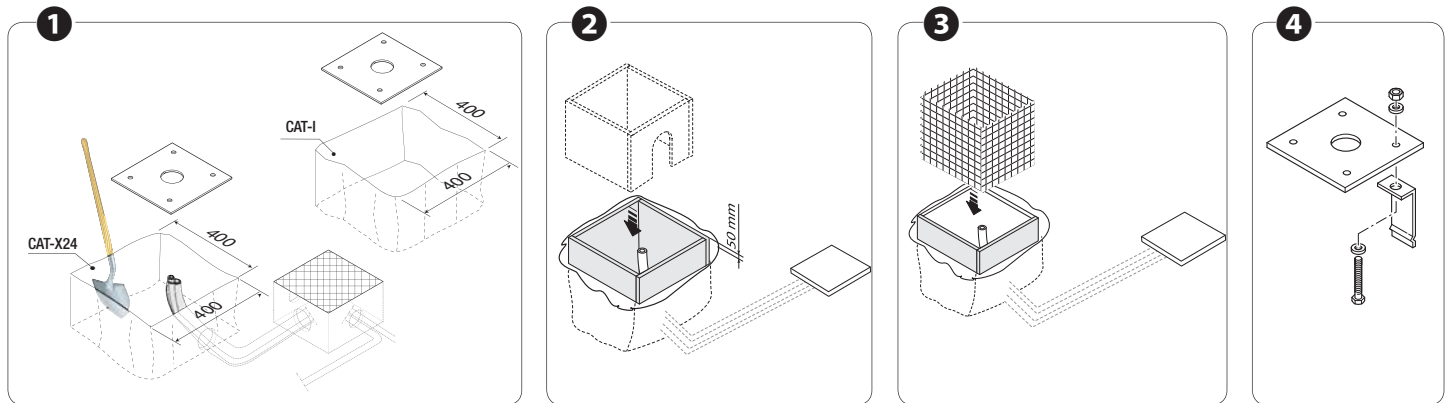

Fill the foundation frame with concrete. The plate must be perfectly level with the bolts which are entirely above surface. Remove the foundation frame and fill the hole with earth around the concrete block.

Fit the electric cables into the tubes so that they come out about 800 mm. Clean the surface.

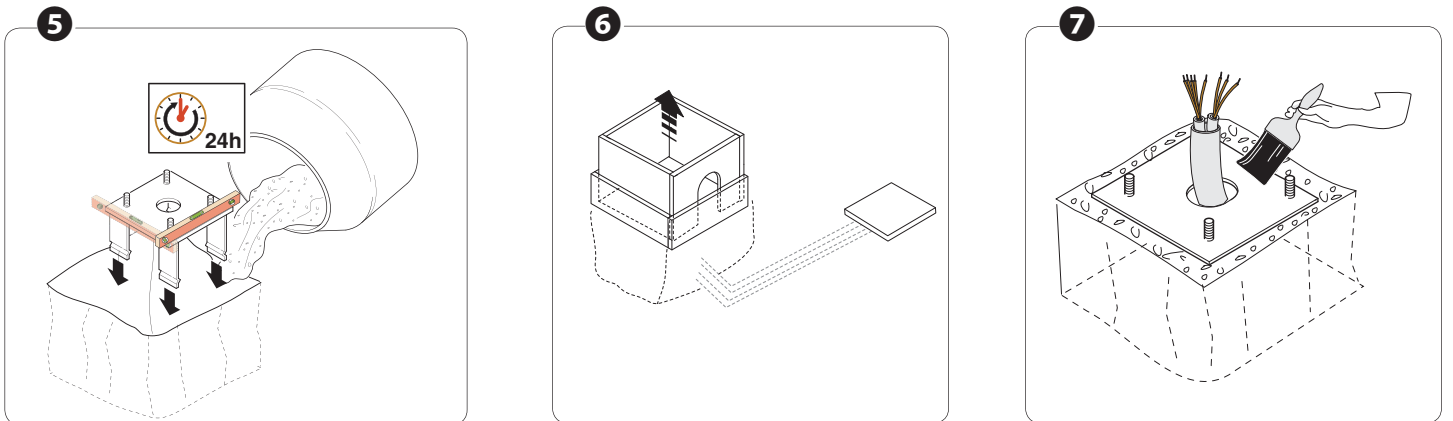

Fastening the pillars

Place the pillars on top of the fastening plates and fasten them using the washers and nuts. ①

Loosen the fastening screws and remove the caps ②; remove the protective carters from the CAT-X24 ③ and free the CAT-I's fixed chain from the binding band ④.

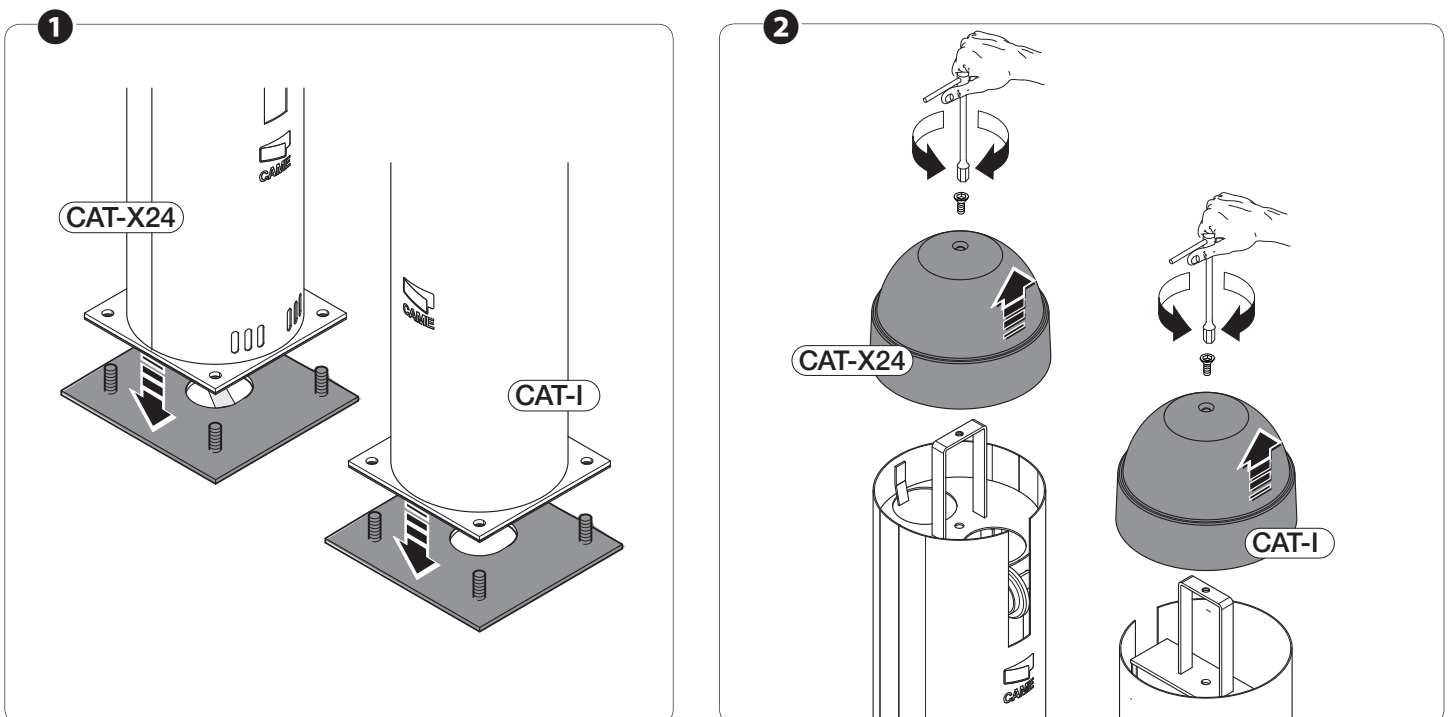

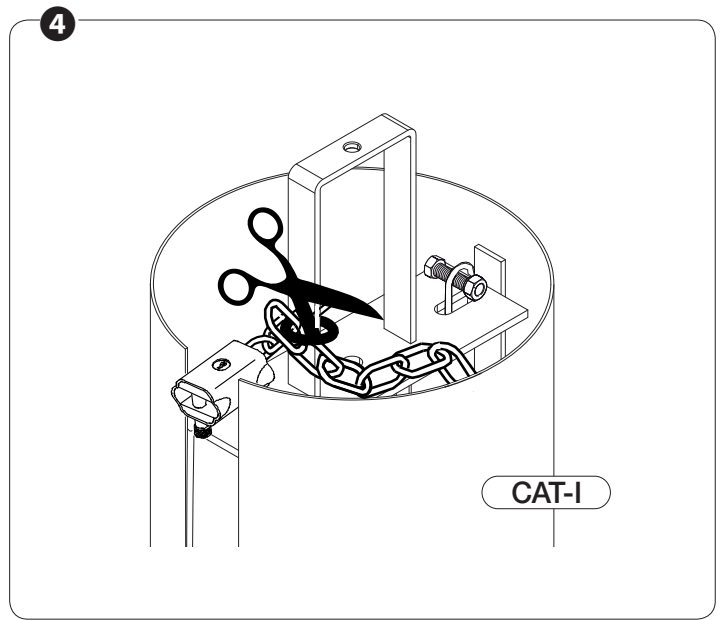
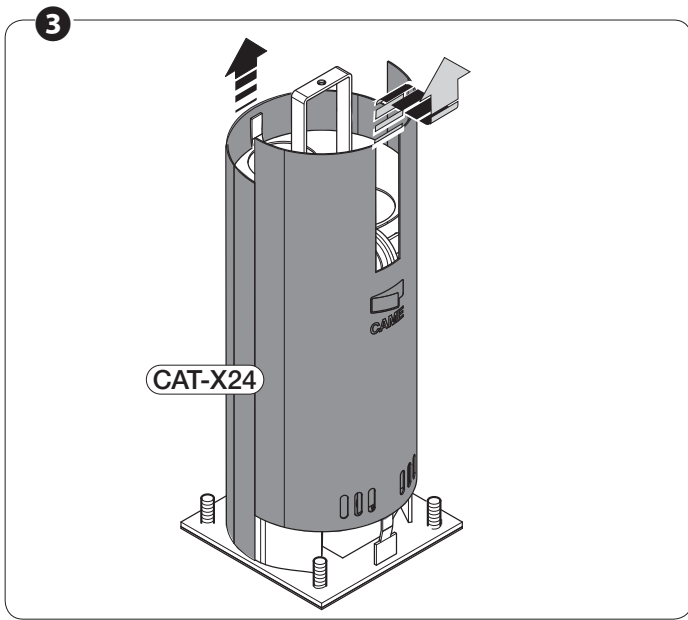

Chain length: L - 500 mm

Fasten the blocking chain to the CAT-X24's service chain **and** using the hooking terminal.

Fasten the other end to the CAT-I's service chain **b**, using the lock **c**.

☞ All final testing and working tests are to be made after the system is completed and the chain is installed.

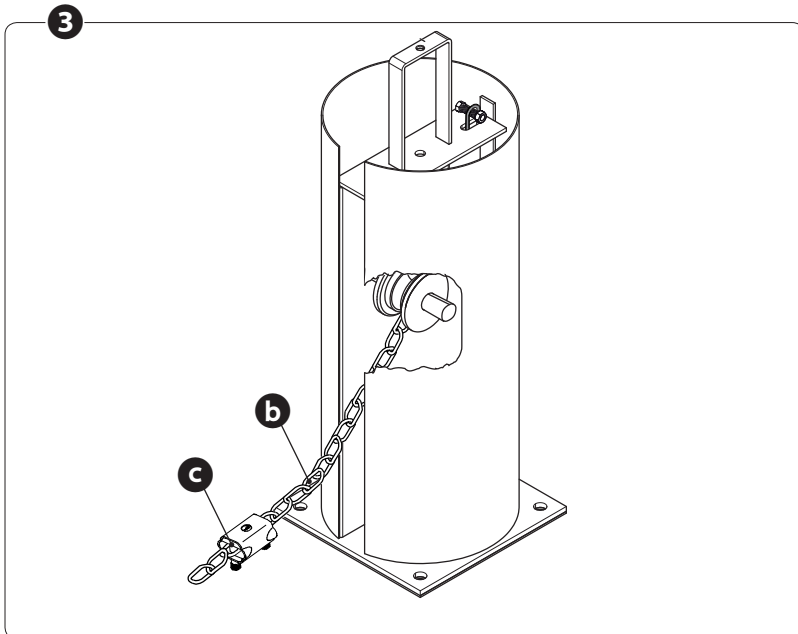
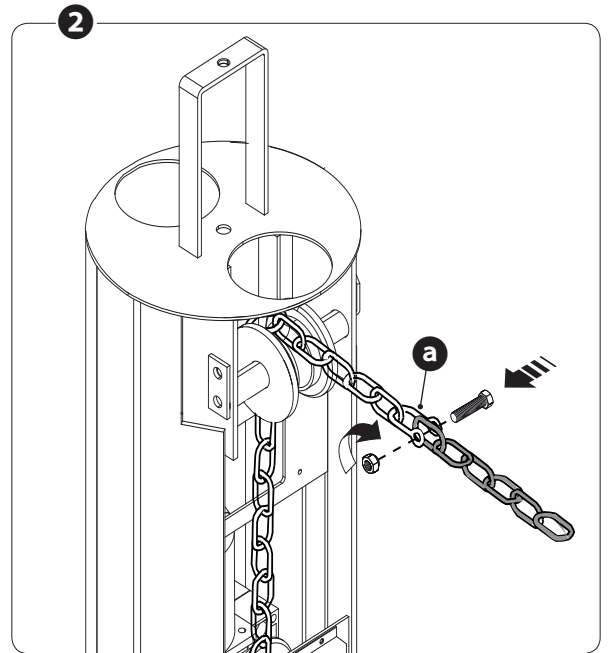
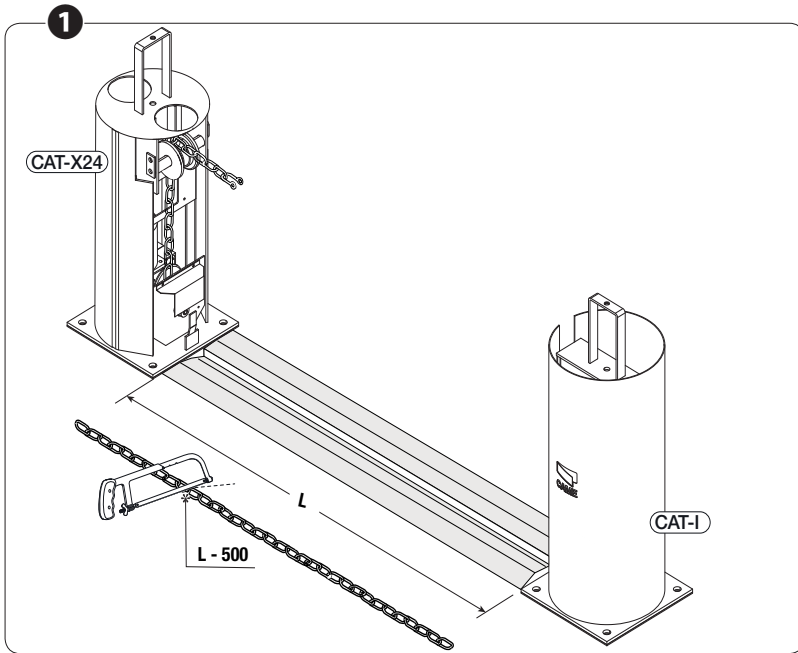

ELECTRICAL CONNECTIONS AND PROGRAMMING (ZL37C)

⚠ Before doing any work on the control panel, cut off the main power supply.

FUSE TABLE

| | |
|--------------------|----------|
| Control board fuse | 3.15 A-F |
|--------------------|----------|

| | |
|------------------|-------|
| Accessories fuse | 2 A-F |
|------------------|-------|

Description of parts

1. Connection terminals
2. Line fuse
3. Accessories fuse
4. Functions selection DIP switches
5. AF card connector
6. T.C.A. trimmer
7. SENS trimmer
8. Radio code memorizing button
9. Warning LED
10. Motor power-supply connectors
11. Connectors for the LB38 card
12. Jumper for selecting command type for button in 2-7
13. 230 V power supply terminals and transformer terminals
14. Limit switch and transformer terminals
15. Transformer connection connectors
16. Transformer

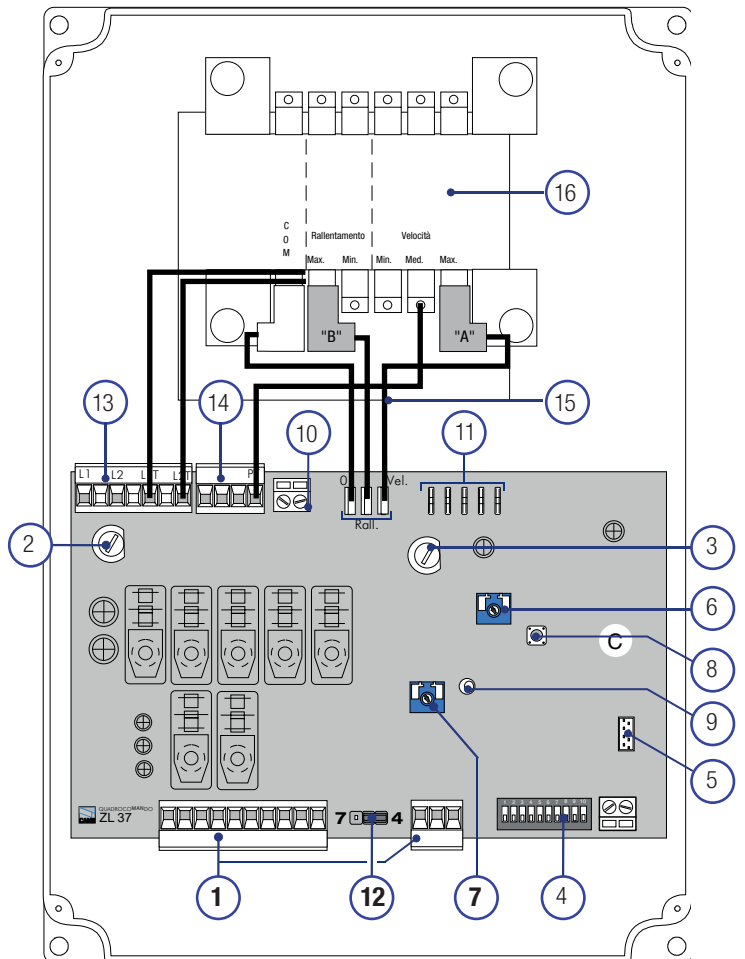

Power supply

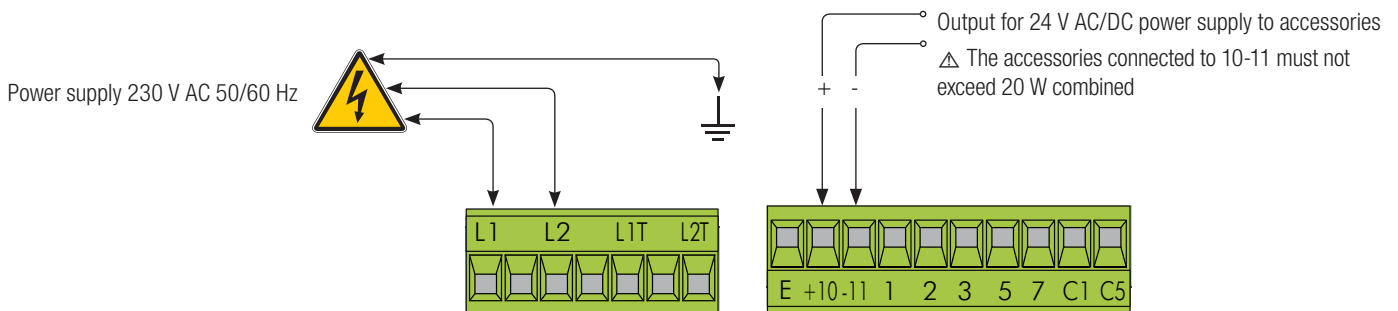

Connecting the gearmotor and limit switches

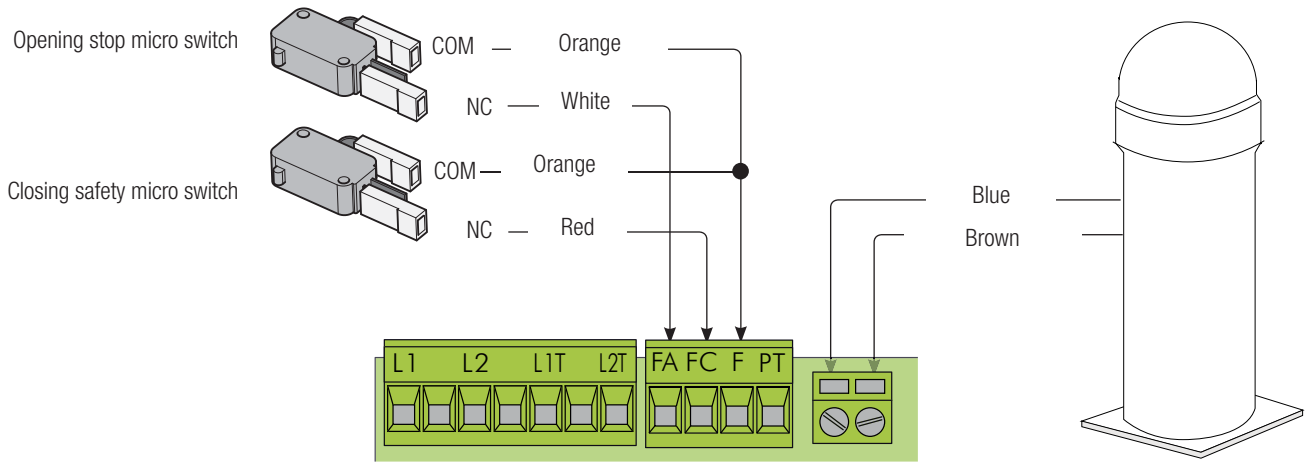

Warning devices

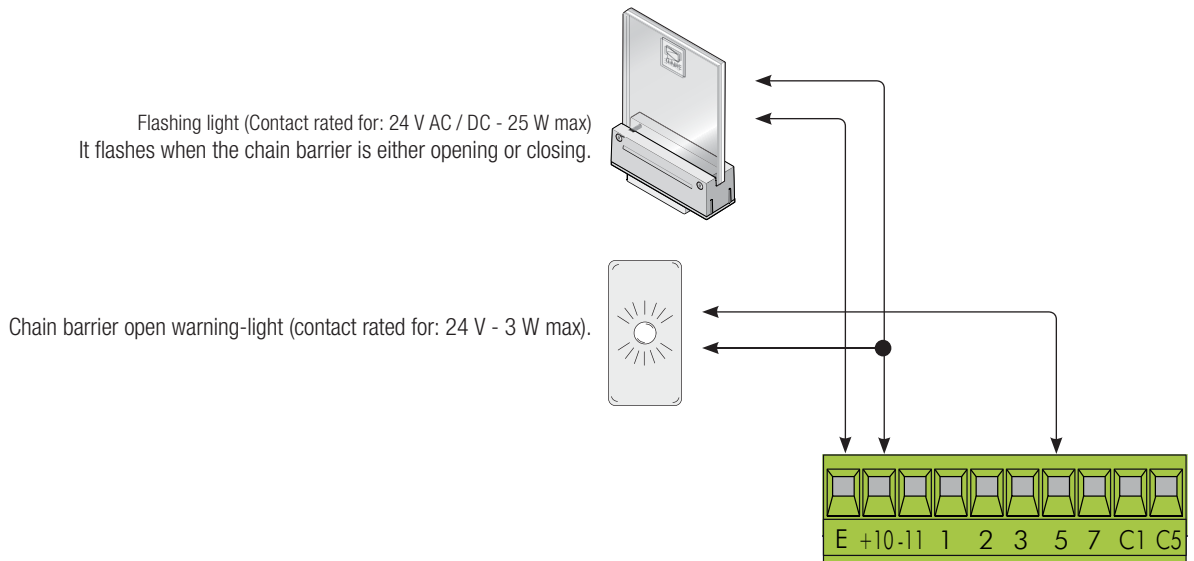

Command and control devices

STOP button (NC contact) For stopping the chain barrier while excluding automatic closing.
To restore movement, press the button or another control device.
If unused set dip switch 9 to ON.

OPEN ONLY button (NO contact)

OPEN-CLOSE-INVERT button (step-by-step) (NO contact)
The jumper must be placed as shown in the figure.

CLOSE ONLY BUTTON (NO contact)
The jumper must be placed as shown in the figure.

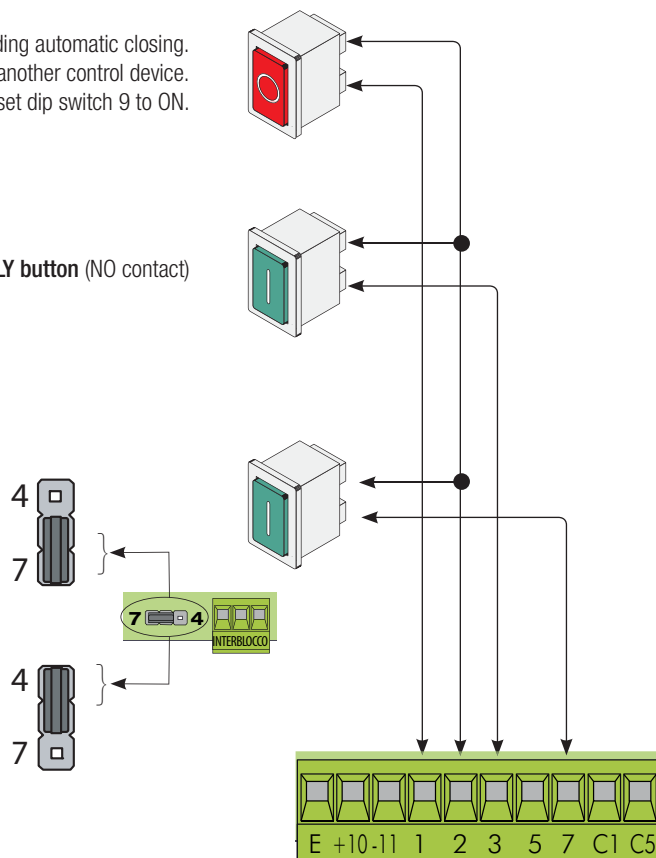

Safety devices

Connect the photocells to 2-C1.

C1: reopening during closing. When the chain barrier is closing, opening the contact triggers the inversion of movement until it is completely open.

△ If unused bridge 2-C1.

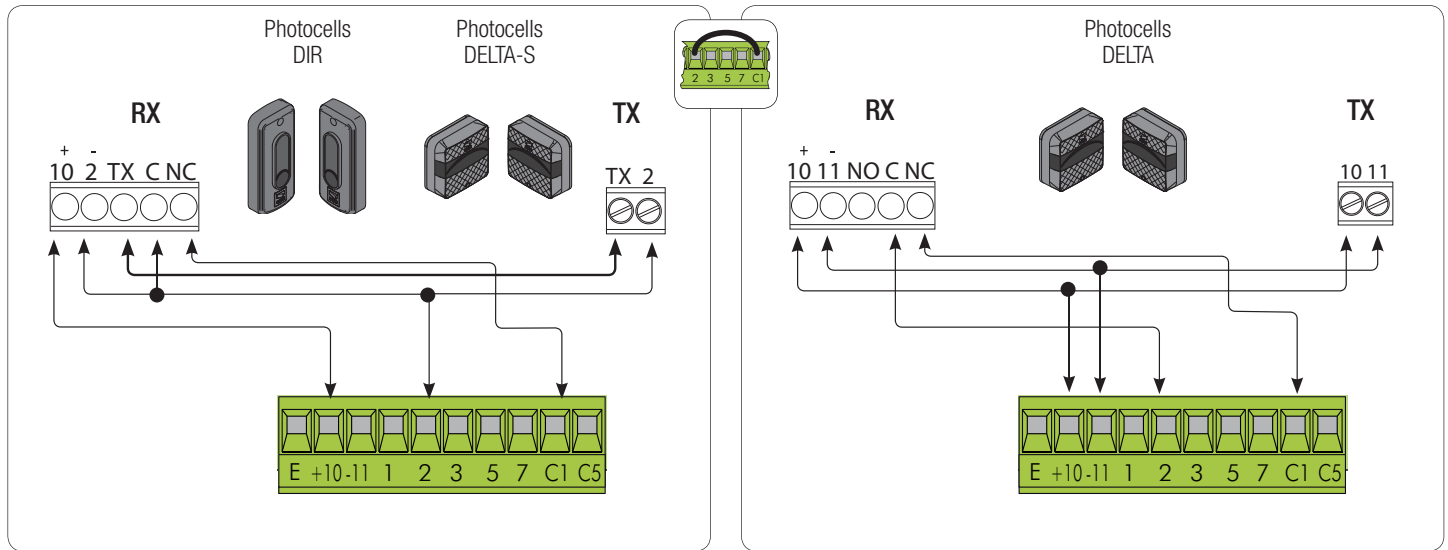

Activating the radio control

△ Before fitting the snap-in card (AF) you MUST CUT OFF THE MAIN POWER SUPPLY and, if present, remove any batteries.

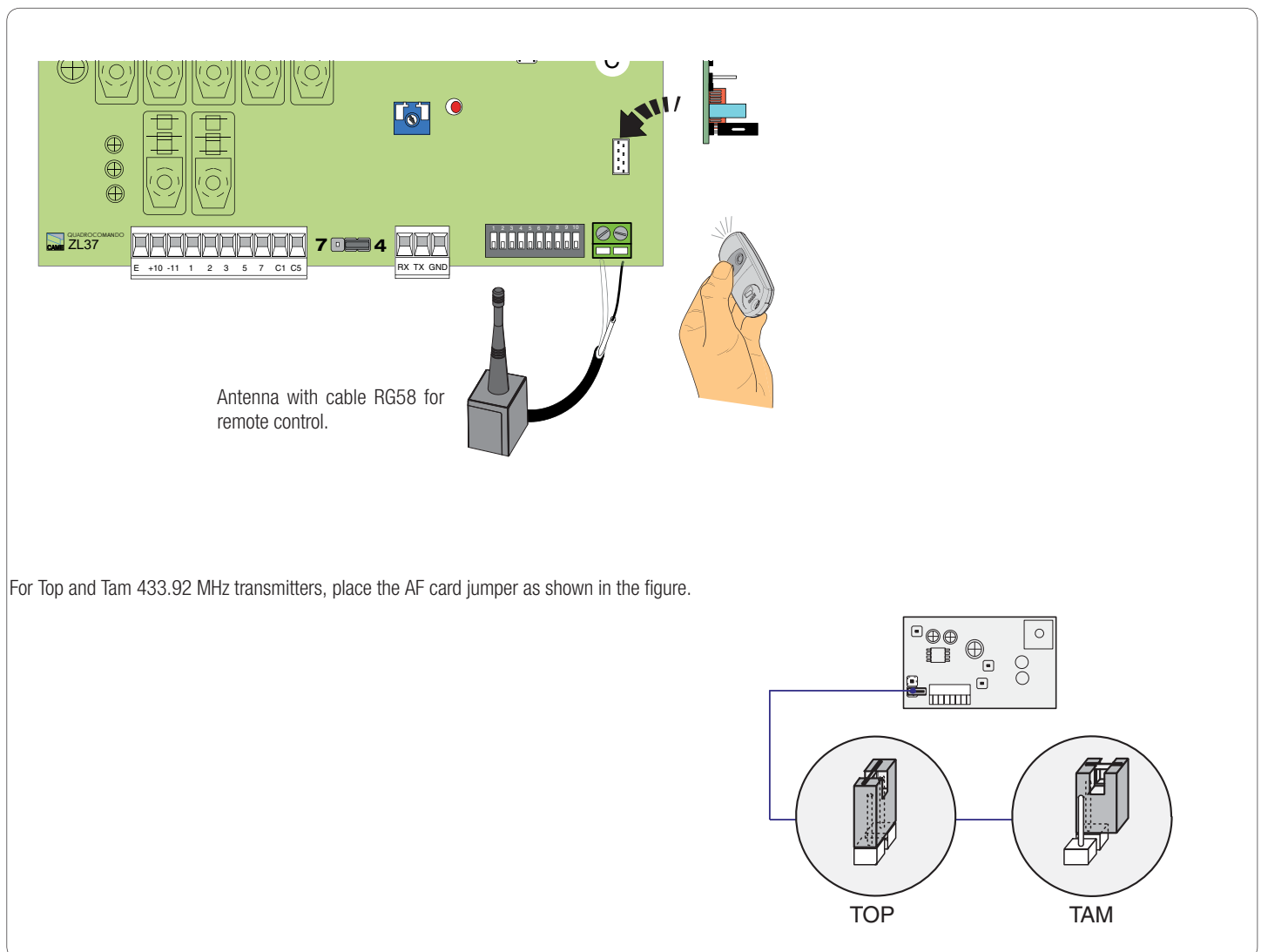

Memorizing

- Keep the PROG key pressed **a** on the control board. The LED flashes **b**.
- Press the key of the transmitter to memorize. The LED stays lit **c** to indicate that memorization has been successful.

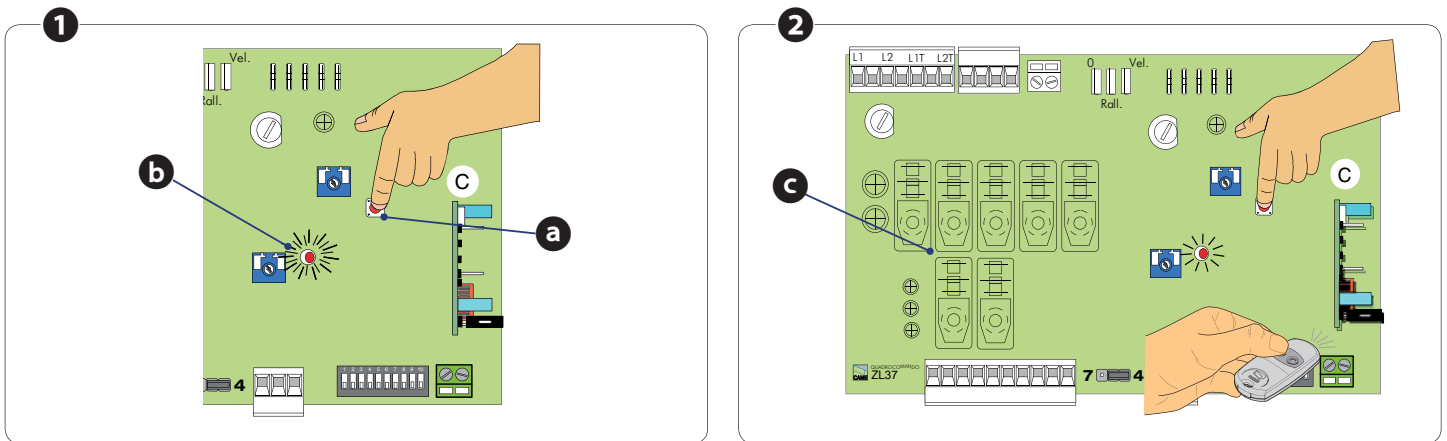

Functions

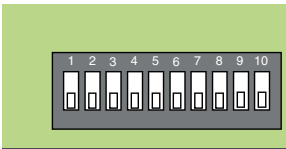

| DIP-SWITCH | Description of functions |
|------------|--|
| 1 ON | AUTOMATIC CLOSING function activated |
| 2 ON | ONLY OPEN function from transmitter and/or button activated |
| 2 OFF | OPEN-CLOSE-INVERT function from transmitter and/or button (2-7) activated |
| 3 ON | The output current on terminals 10-E is 24 V during the movement phases and in when the chain is in the closed position and activated. |
| 3 OFF | The output current on terminals 10-E is 24 V when the chain is in motion and activated. |
| 4 ON | MAINTAINED ACTON function with button activated |
| 5 ON | PRE-FLASHING function while opening and closing activated |
| 6 ON | OBSTRUCTION DETECTION function activated |
| 7 OFF | Not used |
| 8 ON | Set the dip switch to ON and DO NO USE |
| 9 OFF | TOTAL STOP function (1-2) activated |
| 10 OFF | Not used |

Adjusting the trimmers

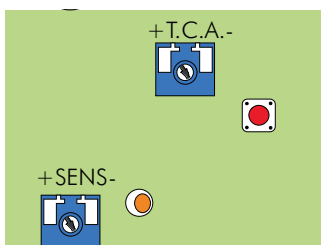

| Trimmer | Description of functions |
|---------|---|
| T.C.A. | <p>Automatic Closing Time</p> <p>It adjusts the chain barrier's waiting time when open. Once this time has elapsed, a closing maneuver takes place. The waiting time can be adjusted to between 1 and 120 s.</p> |
| SENS | <p>Sensitivity</p> <p>It adjusts obstruction detection sensitivity when the chain barrier is moving. Minimum sensitivity (-) or maximum sensitivity (+).</p> |

Establishing the endstop points

-Remove the protective carter **a** to reach the adjusting cam.

When **opening**: already adjusted **b**.

When **closing**: power up and adjust the closing-chain tautness, then rotate the red cam **c** and lock it before setting the micro switch **d**.

The micro switch is for adjusting the chain tautness.

- Replace the carter.

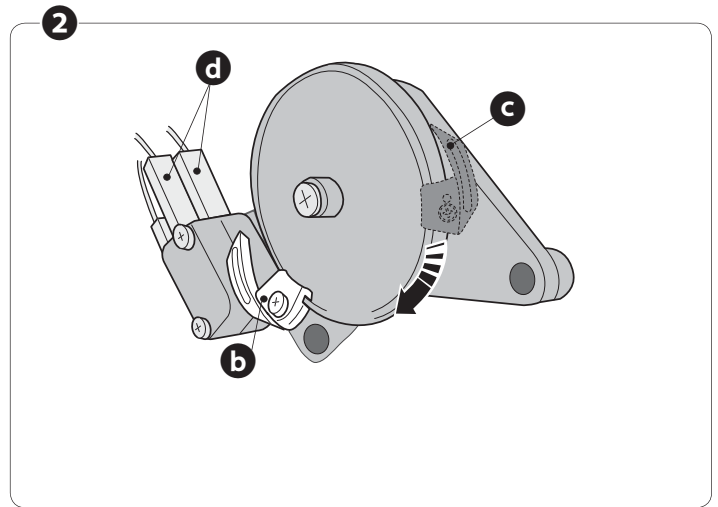
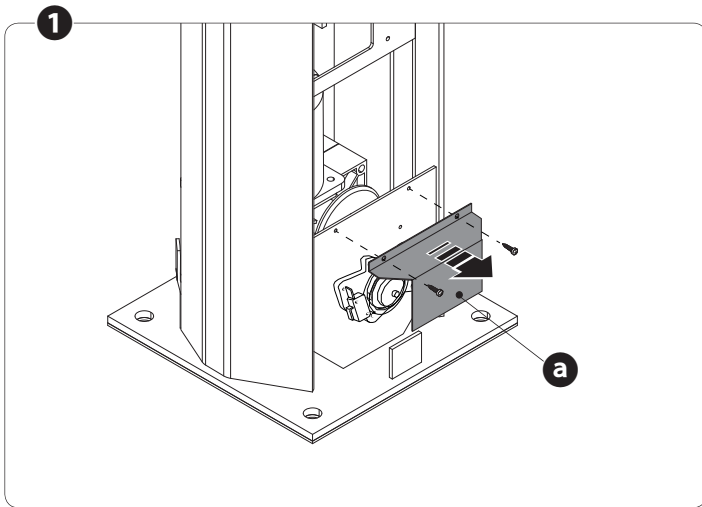

Adjusting speed

Opening / Closing speed: move the faston **Vel. 1 a** to Min (minimum), Med.(medium) or Max. (Maximum).

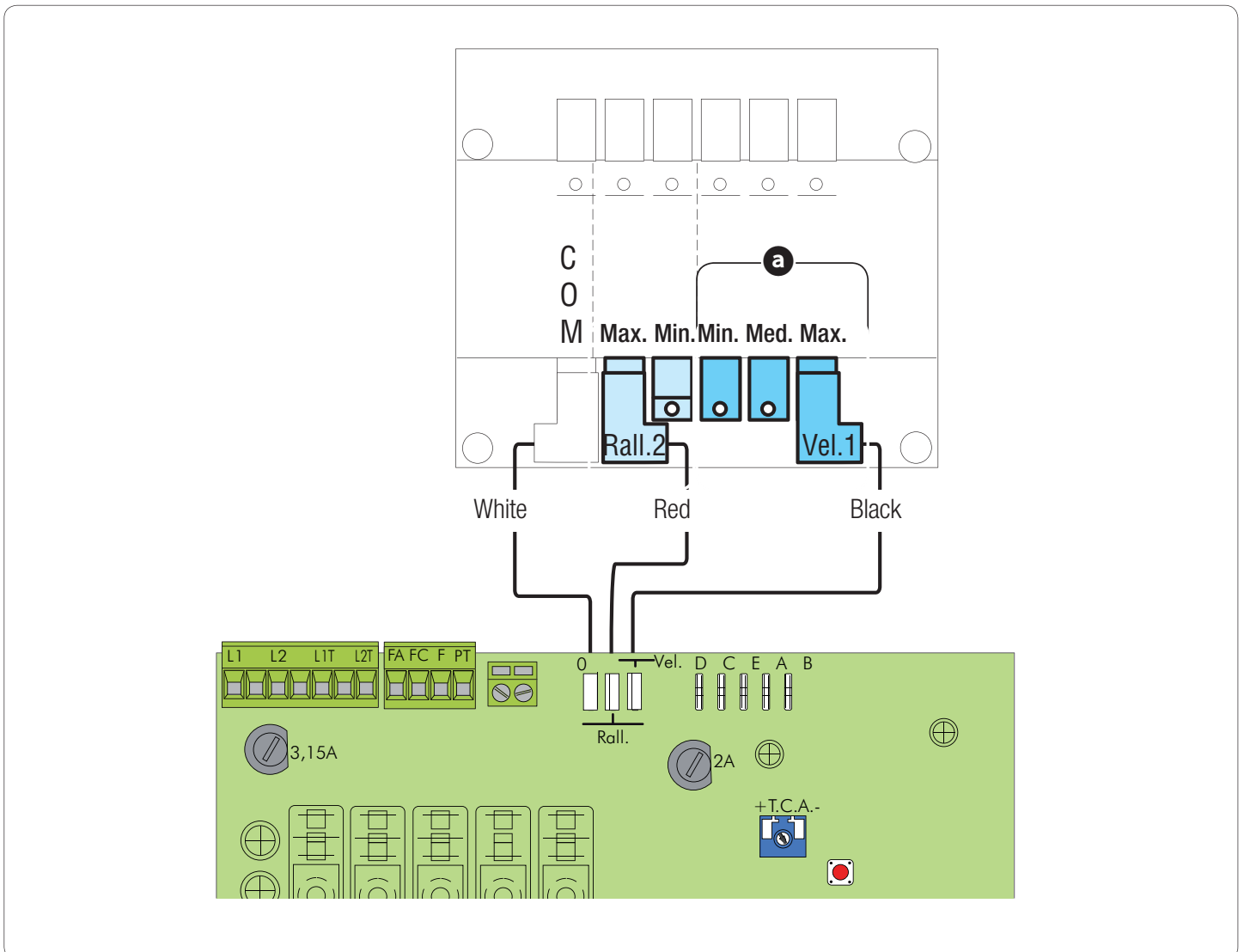

FINAL OPERATIONS

Once you have finished with the electrical connections and grounding, replace the side carters and caps onto both barriers, then fasten them using the screws.

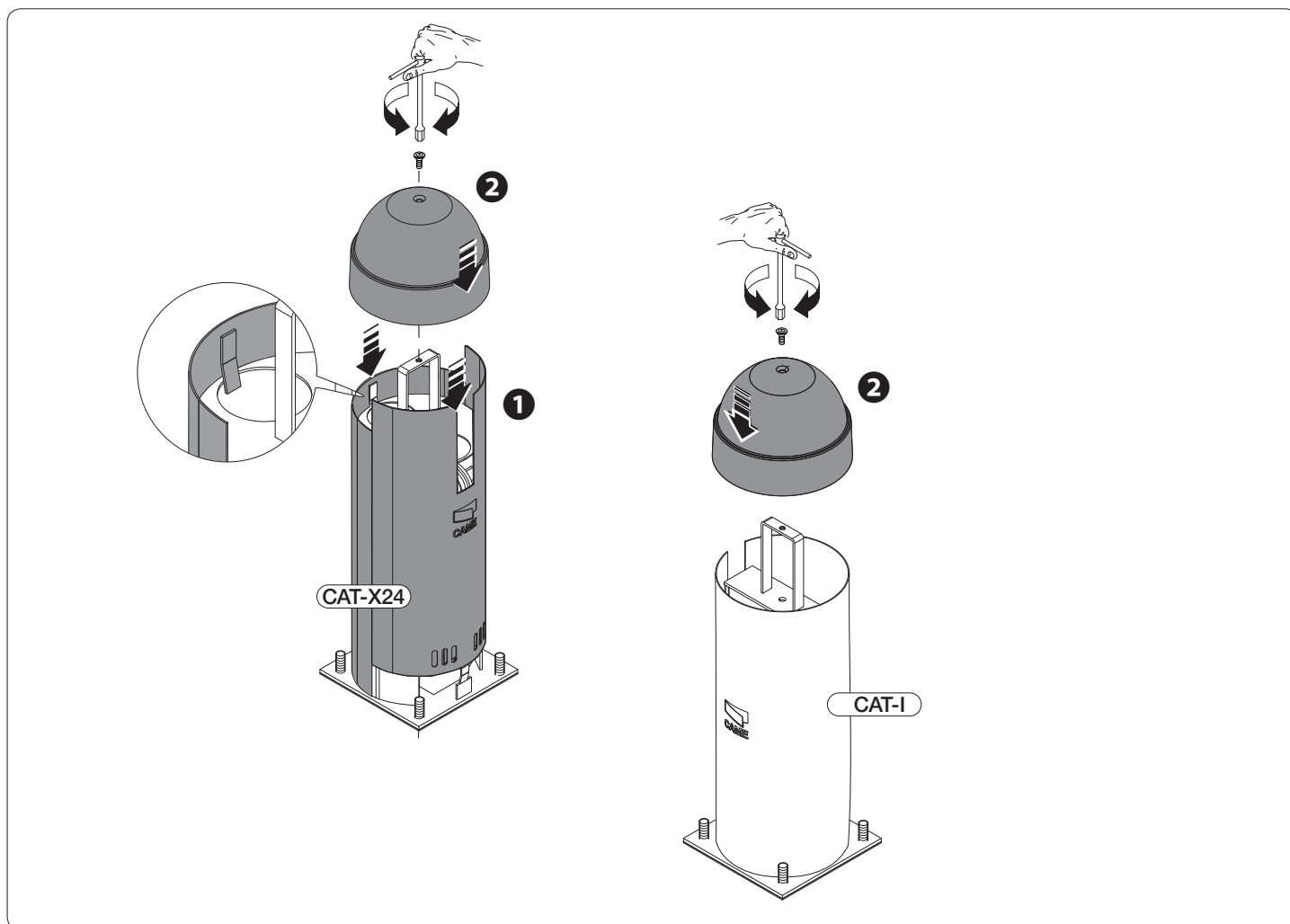

RELEASING THE GEARMOTOR

⚠ This procedure must be done with the main power cut off.

- Swing the small plate out of the way and fit the key into the lock **a** then turn it clockwise.
- Fit the the release lever key **c** and **b** turn it clockwise until the chain releases.
- Pull the chain to help release it.

To lock the gearmotor, turn the release key completely counter clockwise.

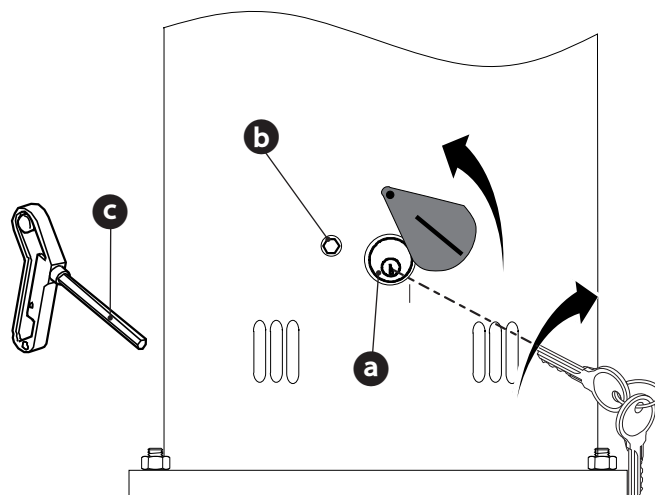

DISMANTLING AND DISPOSAL

☞ CAME CANCELLI AUTOMATICI S.p.A. employs a certified Environmental Management System at its premises, compliant with the UNI EN ISO 14001 standard to ensure the environment is safeguarded.

Please continue safeguarding the environment. At CAME we consider it one of the fundamentals of our operating and market strategies. Simply follow these brief disposal guidelines:

♻️ DISPOSING OF THE PACKAGING

The packaging materials (cardboard, plastic, and so on) should be disposed of as solid urban waste, and simply separated from other waste for recycling. Always make sure you comply with local laws before dismantling and disposing of the product.

DO NOT DISPOSE OF IN NATURE!

♻️ DISMANTLING AND DISPOSAL

Our products are made with different materials. Most of these (aluminum, plastic, iron, electrical cables) is classified as solid urban waste. They can be recycled by separating them before dumping at authorized city dumps.

Whereas other components (control boards, batteries, transmitters, and so on) may contain hazardous pollutants.

These must therefore be disposed of by authorized, certified professional services.

Before disposing, it is always advisable to check with the specific laws that apply in your area.

DO NOT DISPOSE OF IN NATURE!

DECLARATION OF CONFORMITY

Declaration CE - - Came Cancelli Automatici S.p.A. declares that this product complies with the essential requisites and other provisions established by directives **2006/42/CE, 2006/95/CE, 2014/30/UE.**

An original copy of the declaration of conformity is available on request.



English - Manual code: **119GM47EN** v. 3 12/2014 © CAME S.p.A.
The data and information in this manual may be changed at any time and without notice.

- IT** • Per ogni ulteriore informazione su azienda, prodotti e assistenza nella vostra lingua:
- EN** • For any more information on company, products and assistance in your language:
- FR** • Pour toute autre information sur la société, les produits et l'assistance dans votre langue :
- DE** • Weitere Infos über Unternehmen, Produkte und Kundendienst bei:
- ES** • Para cualquier información sobre la empresa, los productos y asistencia en su idioma:
- NL** • Voor meer informatie over het bedrijf, de producten en hulp in uw eigen taal:
- PT** • Para toda e qualquer informação acerca da empresa, de produtos e assistência técnica, em sua língua:
- PL** • Wszystkie inne informacje dotyczące firmy, produktów oraz usług i pomocy technicznej w Waszym języku znajdują się na stronie:
- RU** • Для получения дополнительной информации о компании, продукции и сервисной поддержке на вашем языке:
- HU** • A vállalatra, termékeire és a műszaki szervizre vonatkozó minden további információért az Ön nyelvén:
- HR** • Za sve dodatne informacije o poduzeću, proizvodima i tehničkoj podršci:
- UK** • Для отримання будь-якої іншої інформації про компанію, продукцію та технічну підтримку:



CAMEGROUP

CAME S.p.A.
Via Martiri Della Libertà, 15
31030 **Dosson Di Casier** (TV)
☎ (+39) 0422 4940
📠 (+39) 0422 4941

Assistenza Tecnica/Numero Verde 800 295830