

Stainless Steel Café Banner Solution

Tensator's Café Banner range is a portable solution that can be used for extending or creating indoor or outdoor spaces, easy to install, dismantle and store, the banner is a flexible and cost-effective way to create space with minimal disruption.

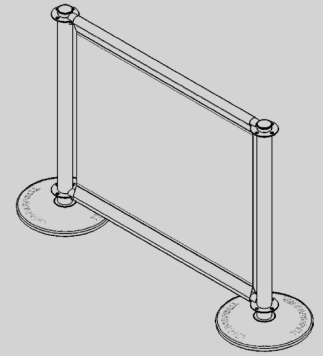

Tensator's Café Banners measure just under 1.5m from post centre to post centre (1330mm).

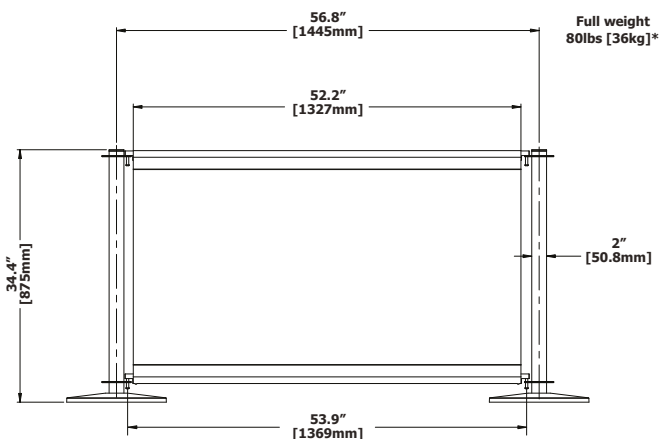

*Posts weigh 17kg individually.

Features & Benefits

- Stainless steel grade of 304, with the opportunity to upgrade to a rust resistant grade of 316 which can be used outside even in areas subject to heavy weather conditions.
- Aluminium rail at the top and bottom, with a stainless steel connector fixing into a stainless steel ring.
- Option of surface fixed or free standing banner systems.
- Three options of banner materials; PVC, Mesh or Canvas.
- Selection of standard banner colours and single or double-sided digital dye prints.
- Customised banners to match your branding, with full colour print options and no cost limitations, banners can also easily be replaced as seasonal offers or messages change.
- Large banner design allows for saleable advertising space.
- Extends your trading area and creates an exterior smoking area.
- 1 year warranty.
- Cost effective, durable and hard wearing dye print that does not scratch or deteriorate.
- Quick and easy to install.
- Keep your customers "inside" your environment whilst seated outside| your establishment.
- In-house design team to assist you in the customisation of your banner.

Product Specification

- Available in three banner materials; PVC, Mesh or Canvas, with plain or digital dye-printed printed banner options, available in any Pantone colour at no extra cost. All banners have a standard 1 year warranty subject to exclusions for non wear and tear damage.
- The heavy weight PVC banner is available in either plain or with customised graphics. PVC banners are water resistant, hardwearing and wipe clean. With a durable high shine finish the PVC banners are well suited for indoor and outdoor use.
- Tensator's mesh banners are easy to handle yet ultra-strong, and designed to withstand the harshest weather conditions. The water resistant, wipe clean banners are suitable for use outside.
- The canvas banner is a premium durable banner option, making it a perfect solution for café environments.

Applications

- Indoor & outdoor events, exhibition halls, shopping centres, pubs, clubs & restaurants, museums, bars & cafés, hotels, leisure clubs, schools.

MILTON KEYNES
+44 1908 684 600

NEW YORK
+1-800-441-0019

DUBAI
+971 4 2997 228

PARIS
+33 1 43 09 85 00

FRANKFURT
+49 69 3003 89 010

WROCLAW
+48 71 359 3800