

# Installation guide

## Night Owl Keep Left Bollard

### 1 & 2 Piece Nightowl

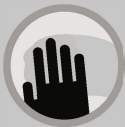

**Cleaning** Products should be rinsed with clean water and then washed with a mild detergent solution using a sponge. Care should be taken not to apply undue pressure that may damage labels. Flush clean with water after washing.

**Manufacturing Standard** LEAFIELD  
Environmental products are manufactured to BS EN ISO 9001: 2008



**PPE** Always wear appropriate PPE equipment and follow safety guidelines.

There are two installation methods:

#### 'Concrete in' Installation

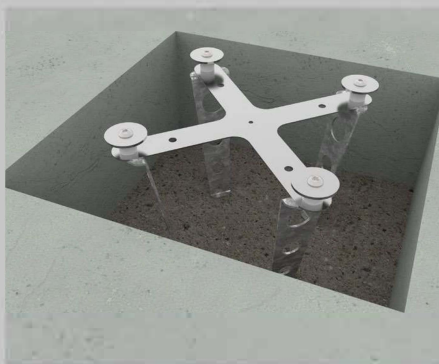

#### 'Surface Mount' Installation



#### Tools

Equipment to excavate foundation hole  
Fast setting structural concrete (Minimum specification C20/25)  
Hardcore / gravel  
Cordless drill + 6 mm Allen key bit  
Torque wrench + 6 mm Allen key bit

10 mm masonry drill bit  
16 mm masonry drill bit  
Appropriate hammer drill  
Cordless drill + 6 mm Allen key bit  
Torque wrench + 6 mm Allen key bit

# 'Concrete in' Installation

## Tools and Components supplied

Allen key 6mm AF  
4x M10 x 40 stainless steel button head screw  
4x M10 x 50 x 3mm Stainless steel washers  
4x Nylon Spacer - Internal diameter 10.6mm x  
outside diameter 22mm x length 20mm  
4x concrete in anchors  
1x Spacer plate

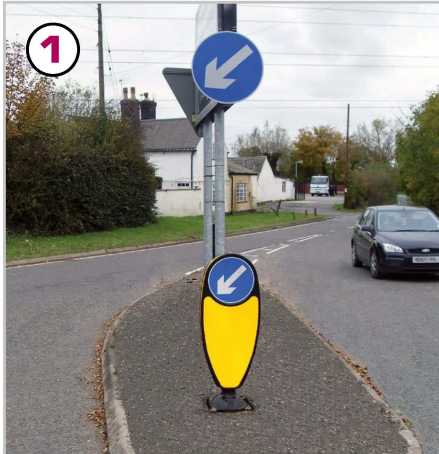

1 Survey the installation site to ascertain suitability for the product and location. Check for buried services and prepare site if necessary.

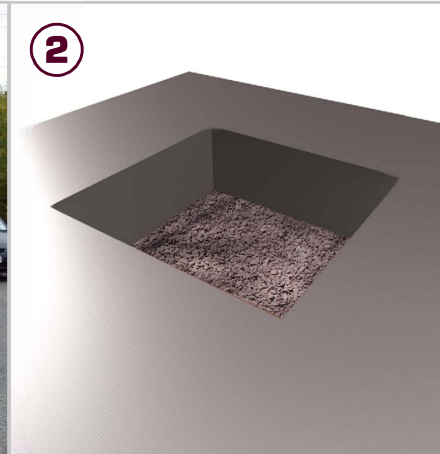

2 Dig a hole of size 550 x 550 x 260mm deep. Fill with 50mm compacted hardcore as illustrated.

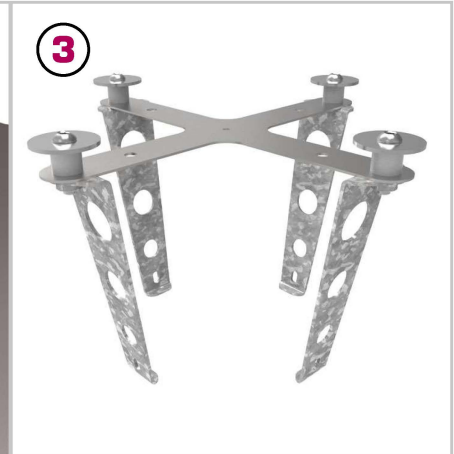

3 Assemble the spacer plate, 4 x anchors, 4 x Nylon spacers, 4 x 50mm washers and 4 x 40mm button head socket screws.

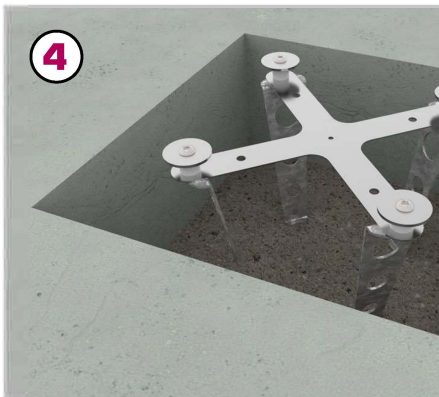

4 Insert the Concrete Ground Anchor keeping a minimum 100mm distance to any edge of the hole. The spacer plate should be flush with the ground level.

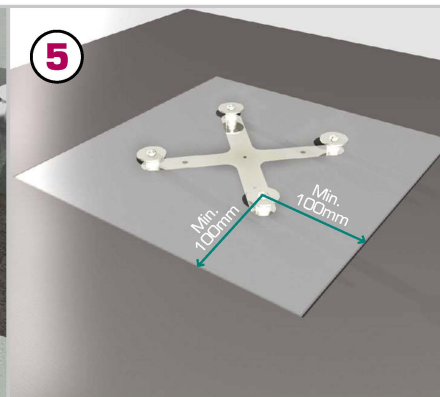

5 Once level and correctly positioned, pour concrete in carefully in order not to displace fixing. Once filled, recheck the placement and adjust accordingly.

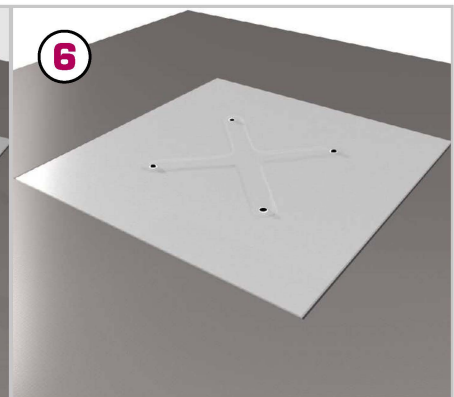

6 When the concrete has set remove bolts, washer, spacers and spacer plate.



7 Place the 4 nylon compression spacers in the 4 moulded holes in the base of the bollard.



8 Position product centering the four holes. Remember to make sure the front of the bollard faces oncoming traffic. Place the large washers over the button head screws and place through the nylon inserts and into the Anchor.



9 The fixing screws should drop down until they reach the threaded part of the Anchor. Make sure all four bolts are engaged in the shield thread by 2 or three turns then proceed to tighten all four bolts to torque setting 27.

# 'Surface Mount' Installation

## Tools and Components supplied

Allen key 6mm AF  
 4x M10 x 100 stainless steel button head screw  
 4x M10 x 50 x 3mm Stainless steel washers  
 4x Nylon Spacer - Internal diameter 10.6mm x outside diameter 22mm x length 20mm  
 4 x shield anchor - Dia 16mm x 60mm, M10 bolt size

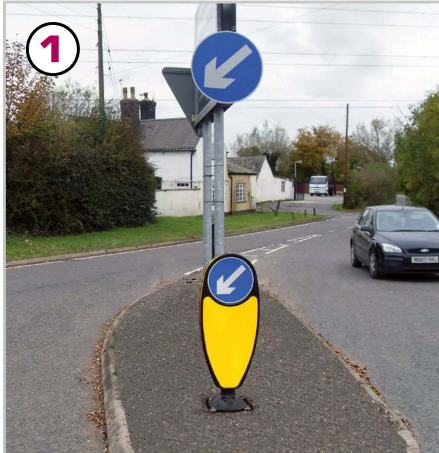

1 Survey the installation site to ascertain suitability for the product and location. Check for buried services and prepare site if necessary.

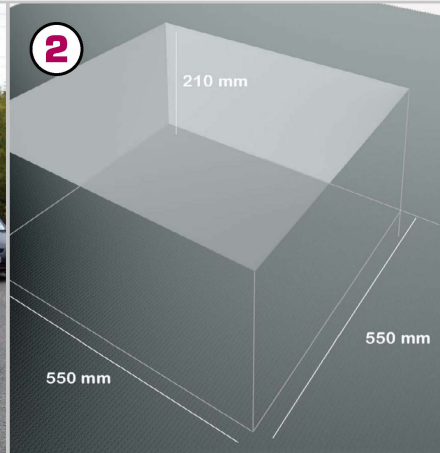

2 The foundation should ideally consist of structural concrete spec (min c20/25) and be of size 550 x 550 x 210mm deep.

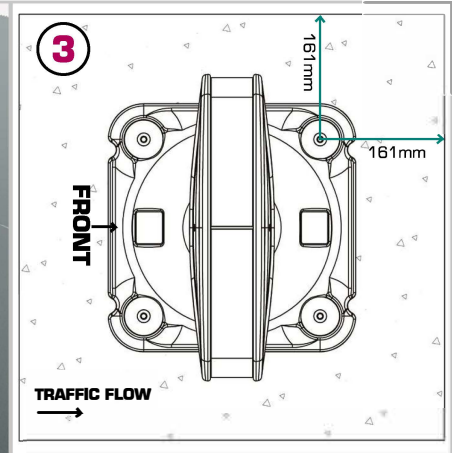

3 Put product in place. The minimum distance from the anchor to the edge of the concrete should be no less than 160mm. "Front" text on the base of the bollard should be facing oncoming traffic.



4 Place the 4 nylon compression spacers in the 4 moulded holes in the base of the bollard.



5 Using the product base (with nylon spacers fitted) as a jig, drill 10mm diameter holes to a depth of approximately 5-10mm, to mark hole centres.

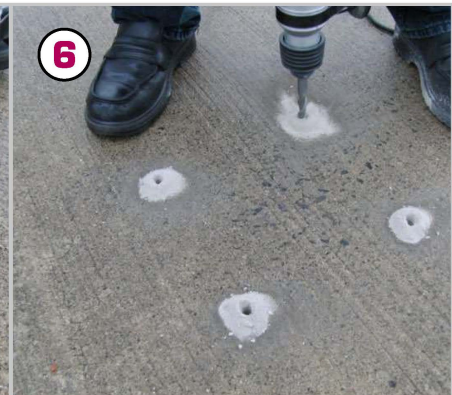

6 Remove bollard and continue to drill out 4 holes a total of 80 - 90mm depth using a 16 mm masonry drill bit. Remove all loose debris from the holes.



7 Screw the 100mm button head screws into the anchor shields so the thread end is just past the base of the anchor. Ease into the holes until the top of the anchor is flush with ground level. Tap lightly with a hammer if necessary.



8 Position product centering the four holes. Remember to make sure the front of the bollard faces oncoming traffic. Place the large washers over the button head screws and place through the nylon inserts and into the Anchor.



9 The fixing screws should drop down until they reach the threaded part of the shield. Make sure all four bolts are engaged in the shield thread by 2 or three turns then proceed to tighten all four bolts to torque setting 27.